

ATTACHMENT I

(Pictures of the EUT and Electrical Schemes)

1 PICTURES

Front



Side

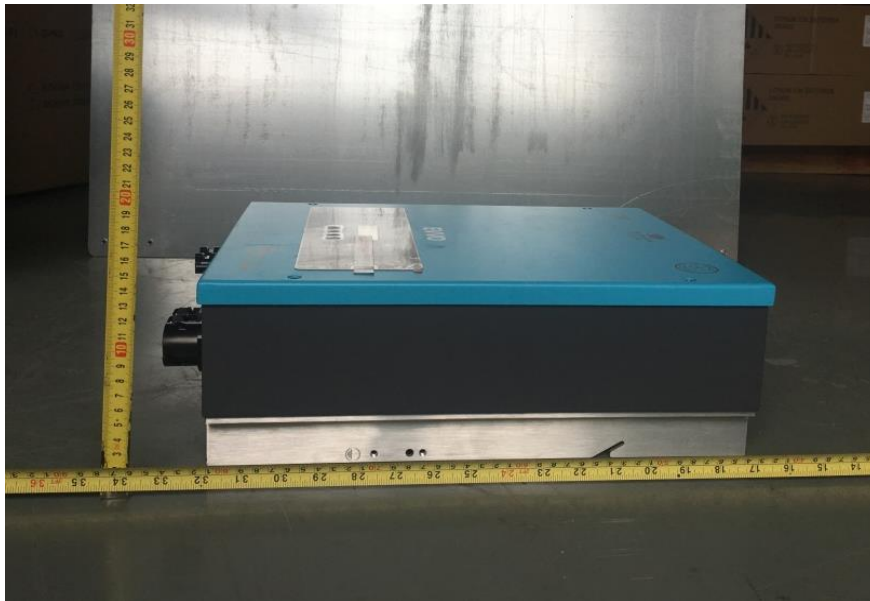

Connection interface



Back Side

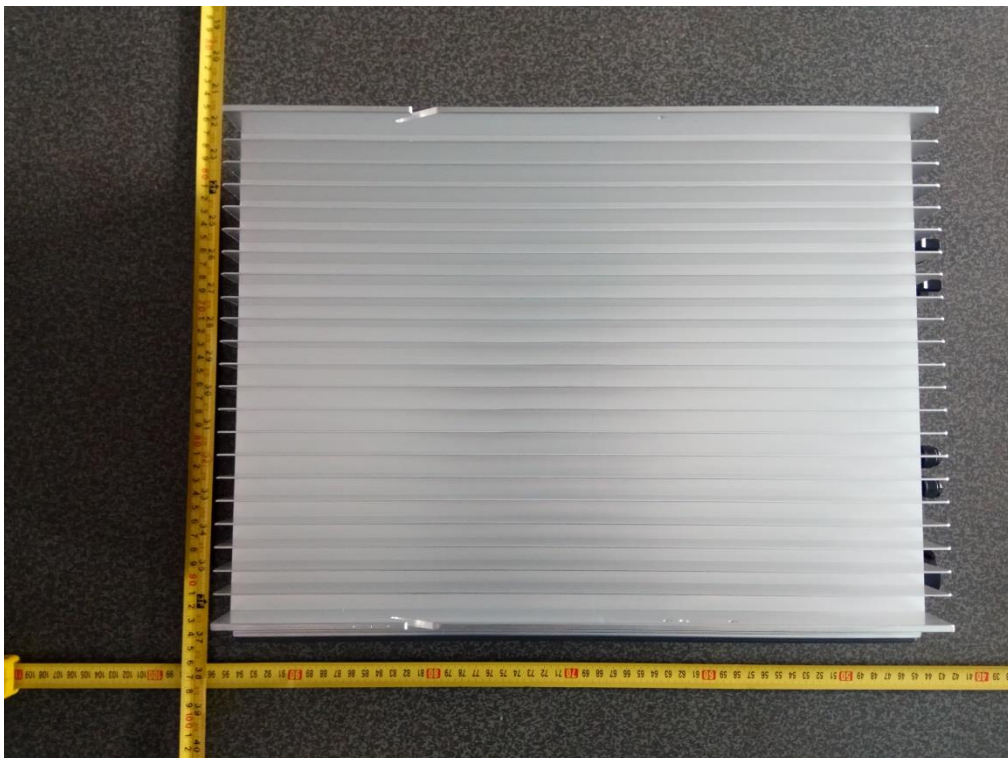

Internal

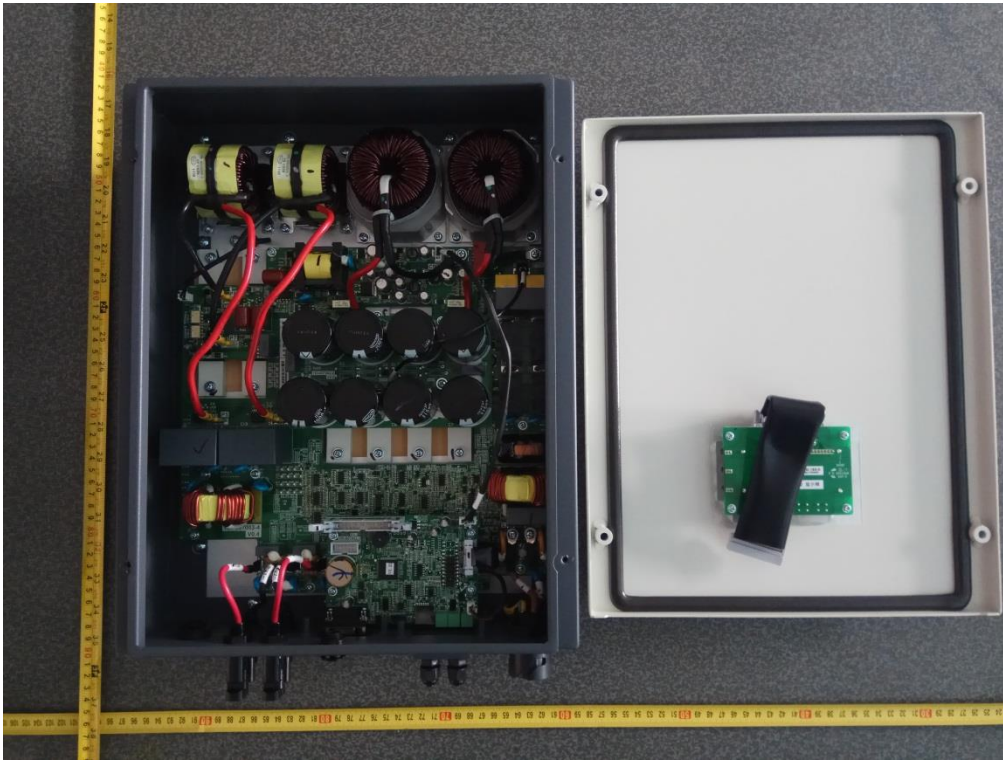

Internal



Front side of communication board

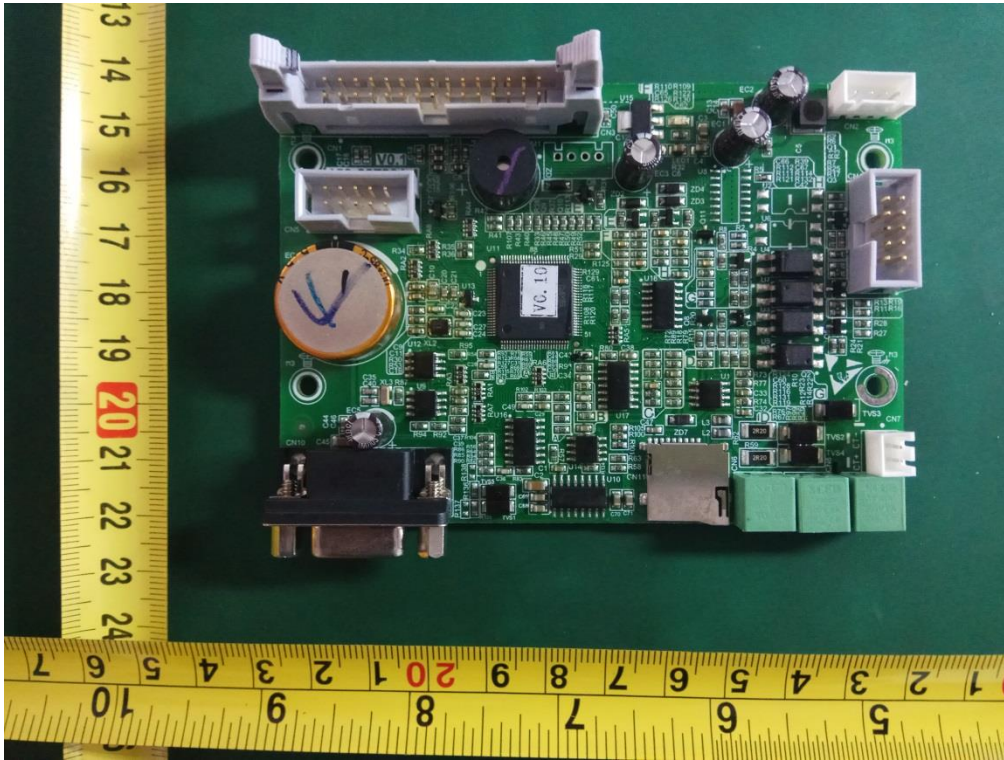

Back side of communication board

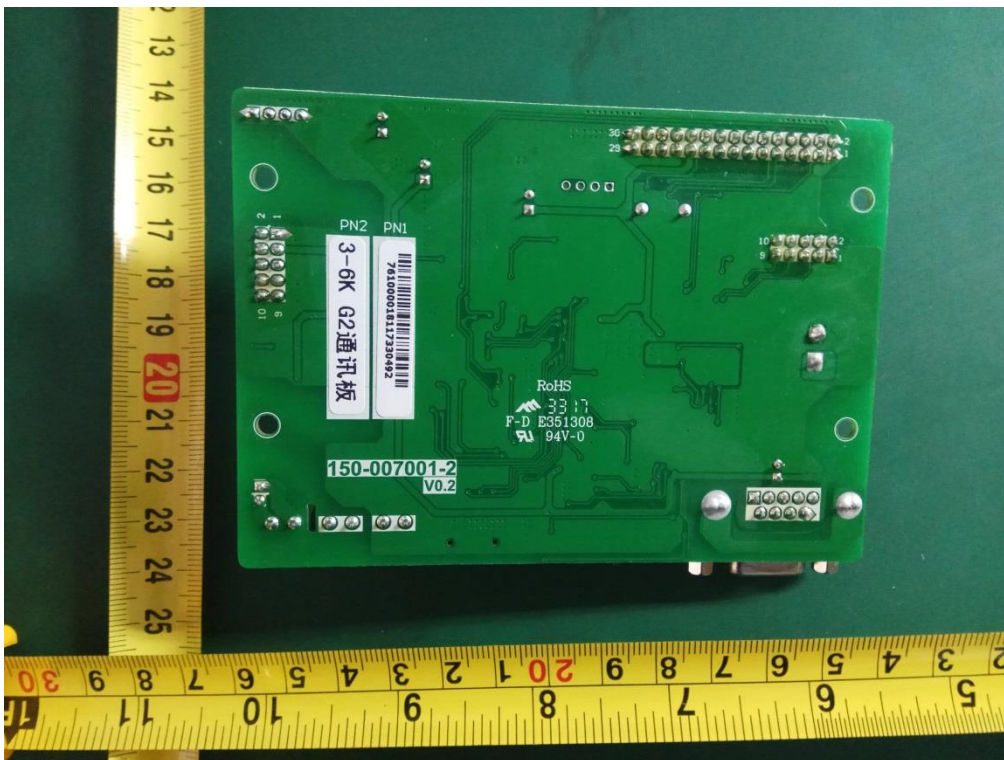

IEC 62116:2014 (50Hz)

Front side of Main board

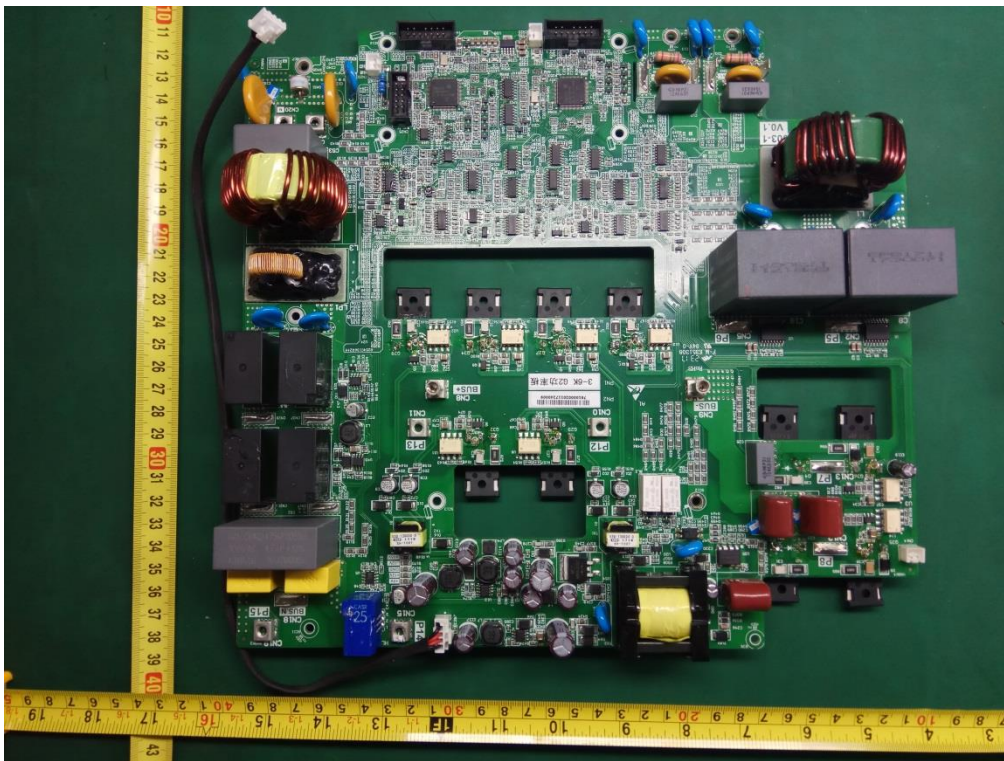

Front side of Main board

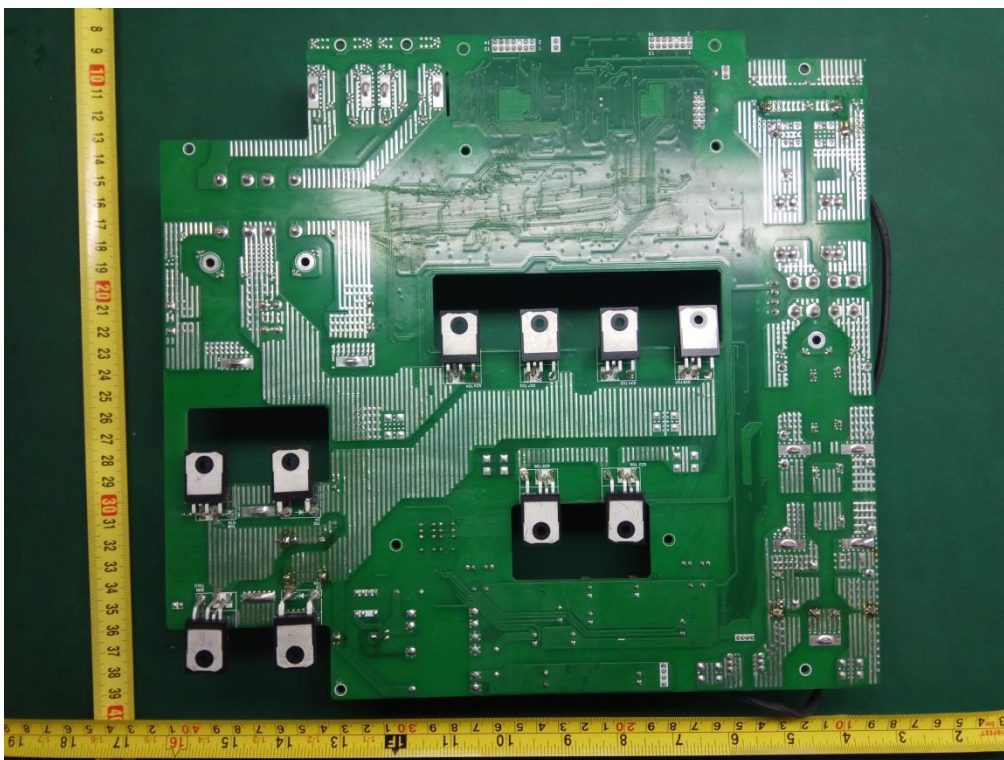

Front side of Bus capacitors board

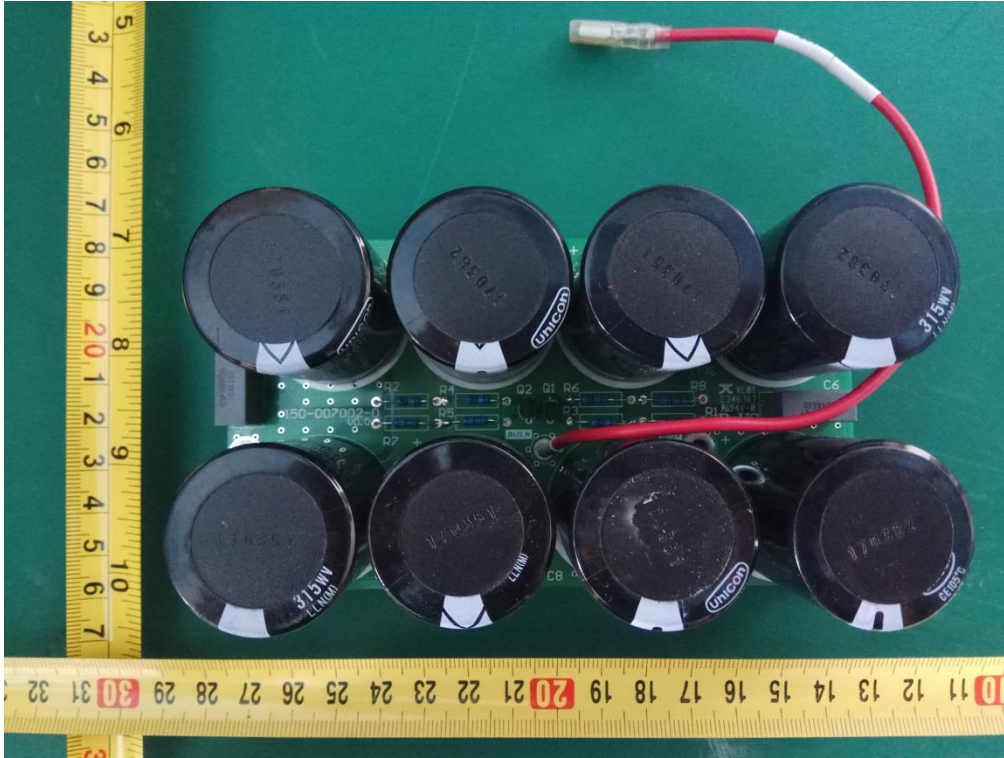

Back side of Bus capacitors board

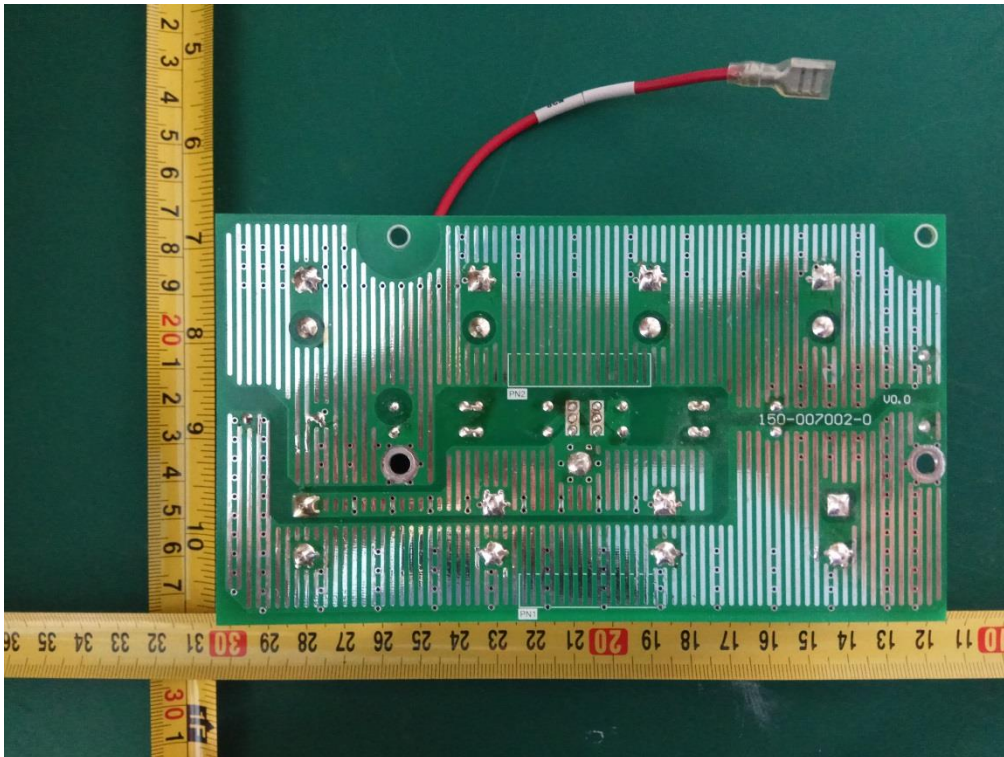

Front side of display board

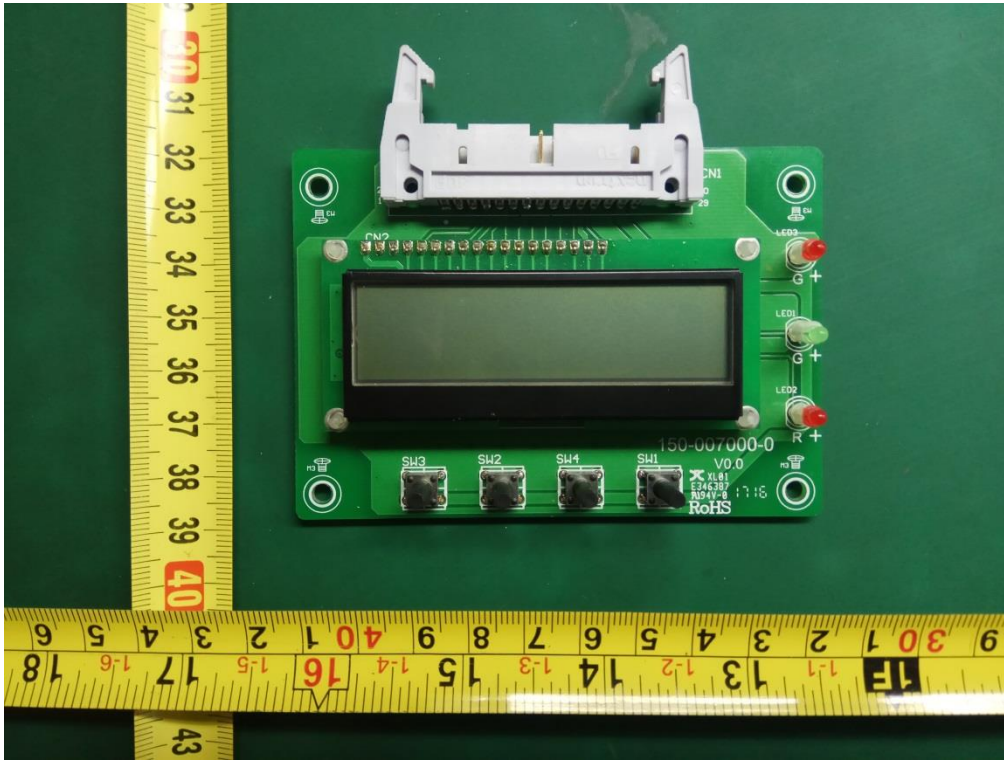

Back side of display board

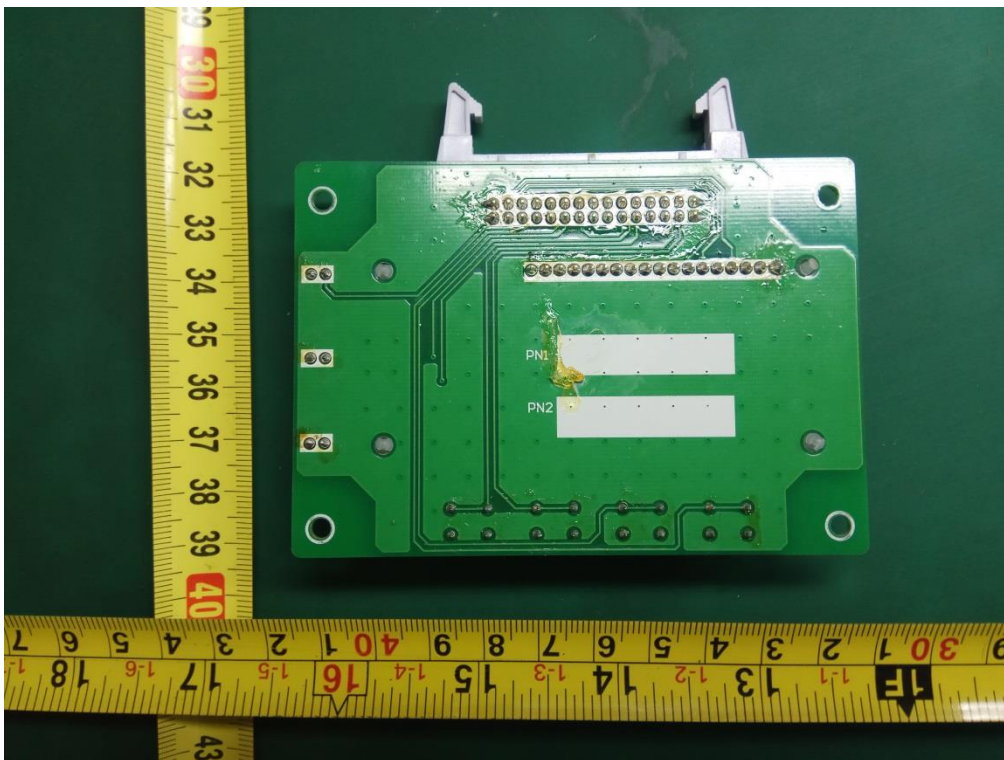

Removed all PCBAs

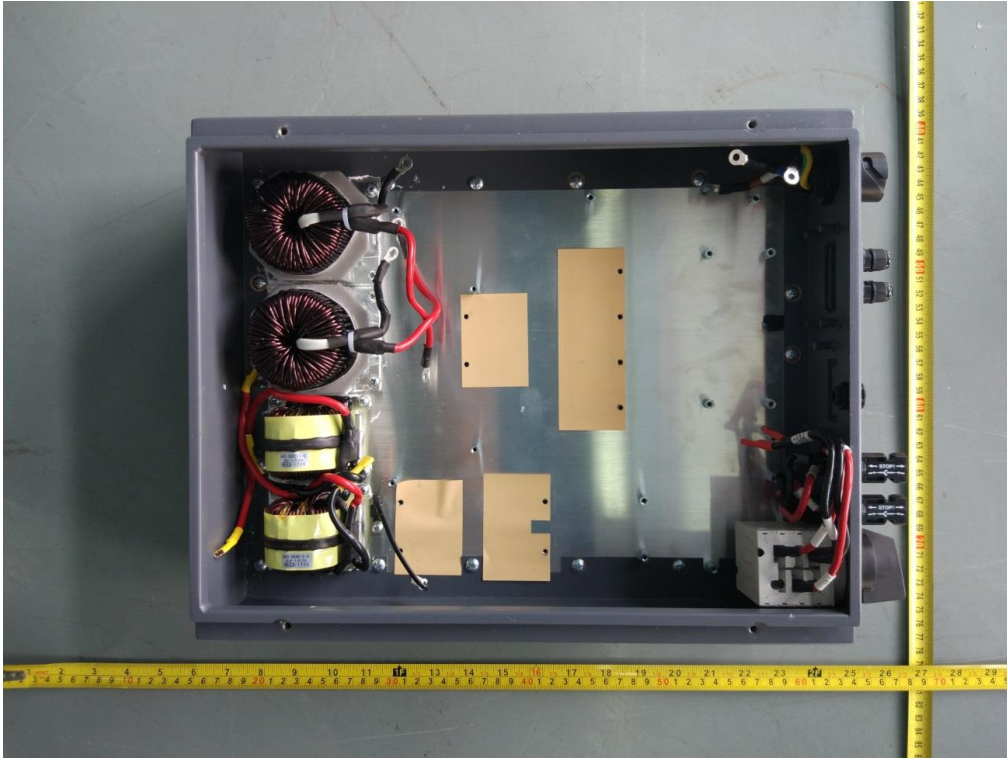

Cover

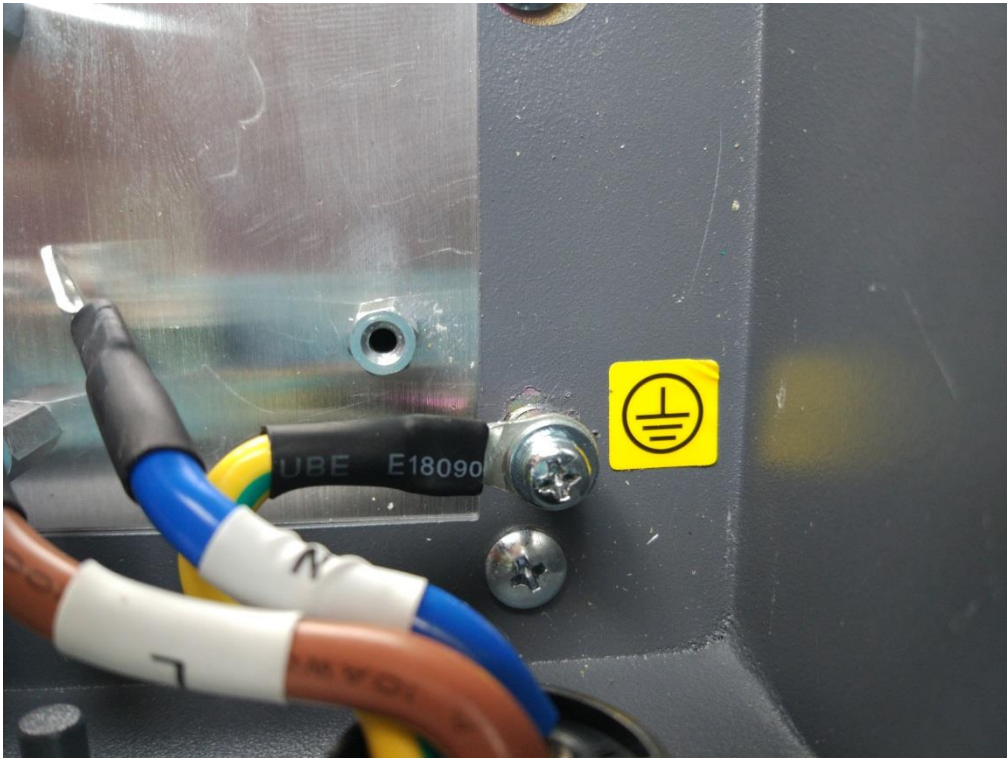

IEC 62116:2014 (50Hz)

Labels

EVVO		Solar Grid-tied Inverter
Model No:	EVVO 6000TLG2	
Max.DC Input Voltage	600V	
Operating MPPT Voltage Range	90-580V	
Max. Input Current	2x11A	
Max. PV Isc	2x13.2A	
Nominal Grid Voltage	230V	
Max. Output Current	27.3A	
Nominal Grid Frequency	50/60Hz	
Nominal Output Power	6000W	
Max. Output Power	6000VA	
Power Factor	1 (adjustable +/-0.8)	
Ingress Protection	IP65	
Operating Temperature Range	-25°C ~ +60°C	
Protection Class	Class I	
Inverter Topology	Non-Isolated	
Factory - Shenzhen China		
Manufacturer : EVOLVE ENERGY GROUP CO., LIMITED		
Address : RM 702, 7/F FU FAI COMM CTR 27 HILLIER ST		
SHEUNG WAN, HK		
Global Head Quarters		
371 Sidco Industrial Estate		
Chennai 600098 India		
VDE0126-1-1, G99, EN50438, AS4777, IEC62116, IEC61727		

Software Version



IEC 62116:2014 (50Hz)

Serial Number of the EUT

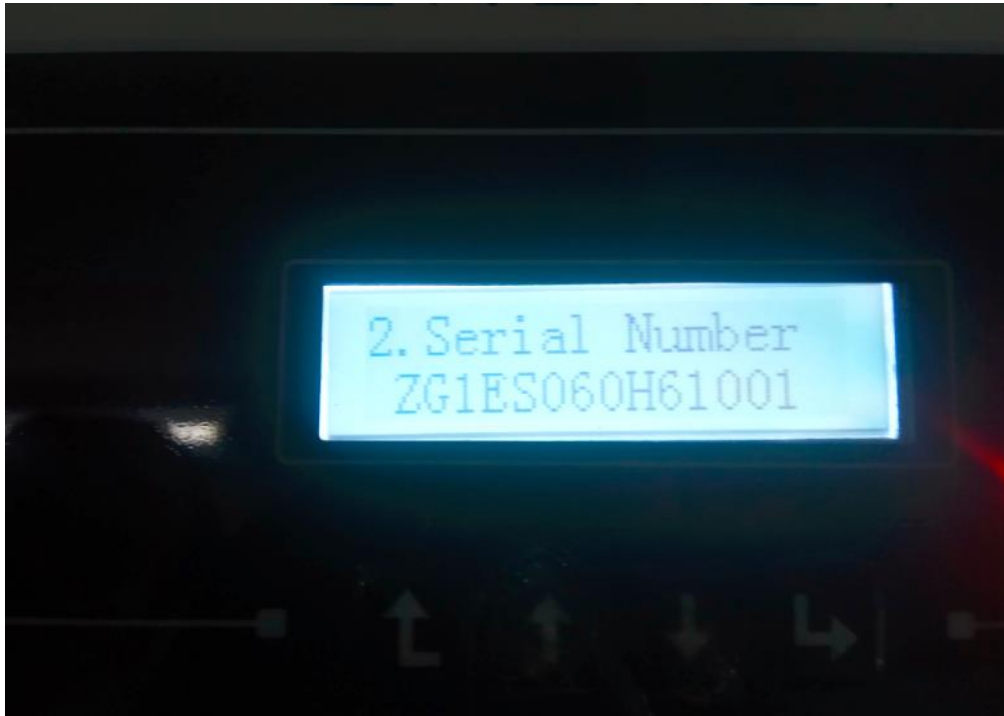

2 ELECTRICAL SCHEMES

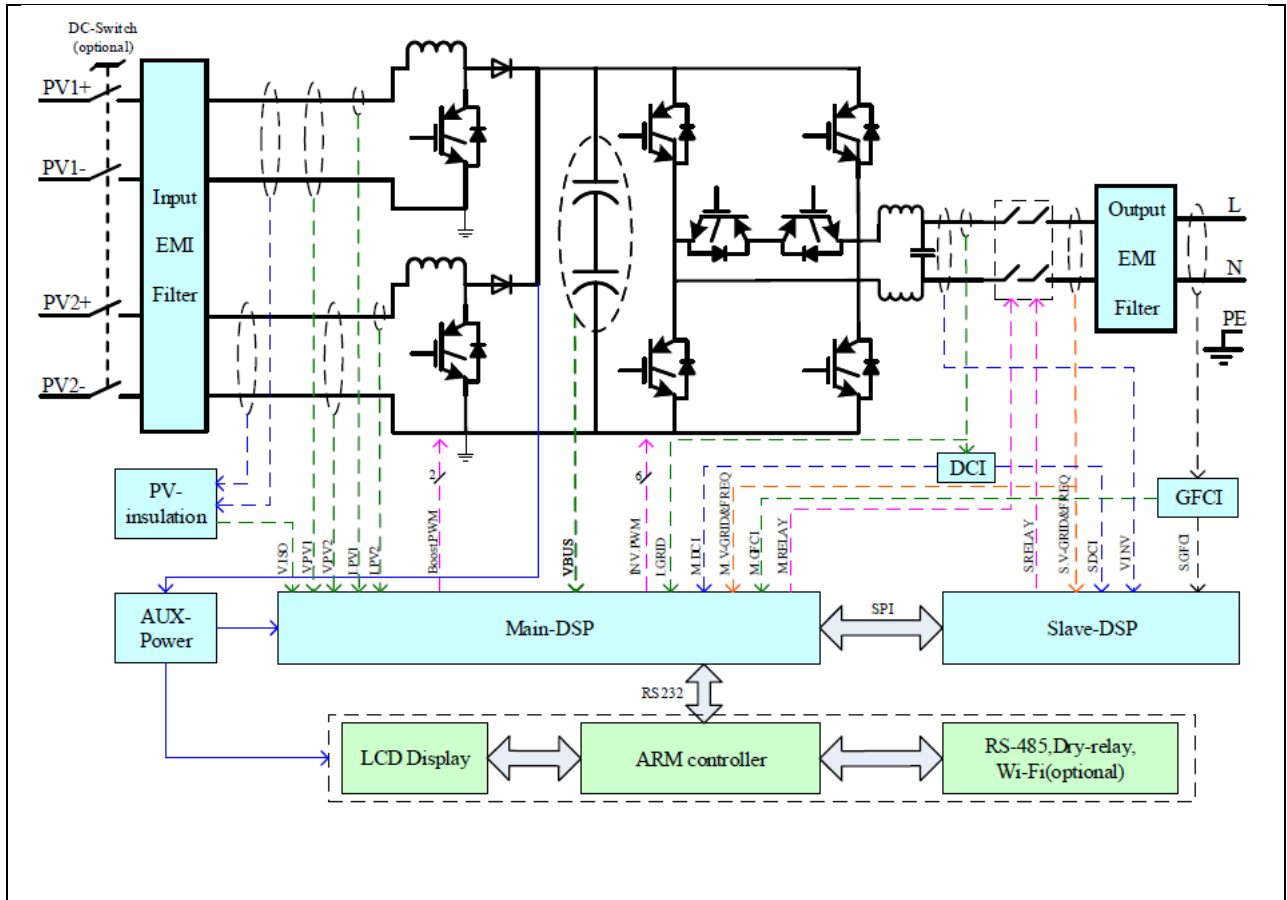

ATTACHMENT II

(GRAPHICS OF THE TEST RESULTS)

Test Condition A

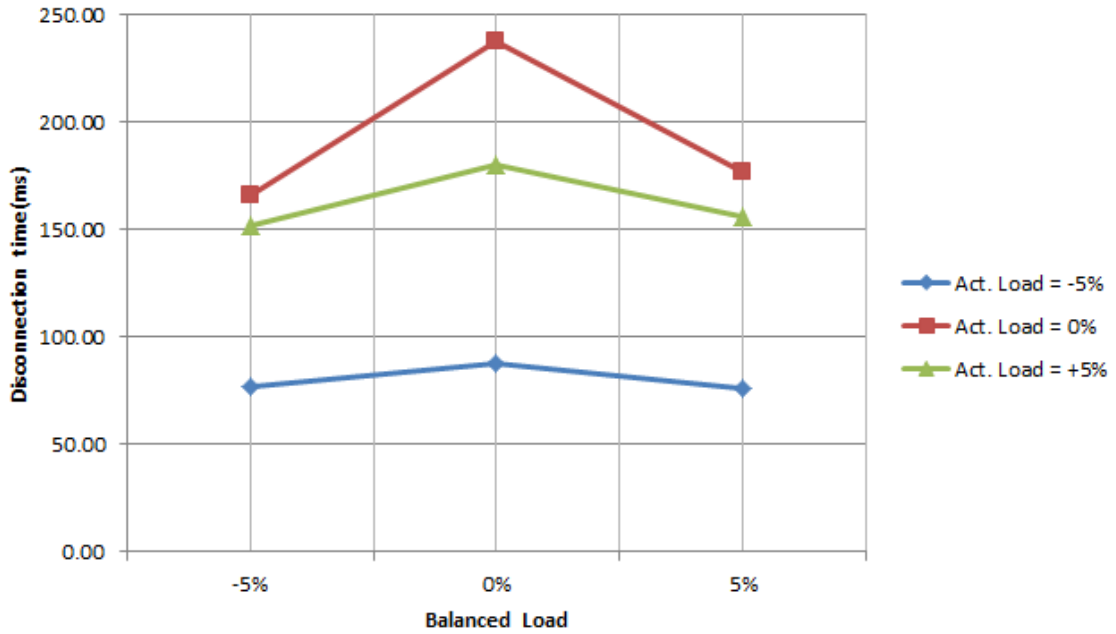

Test Condition B

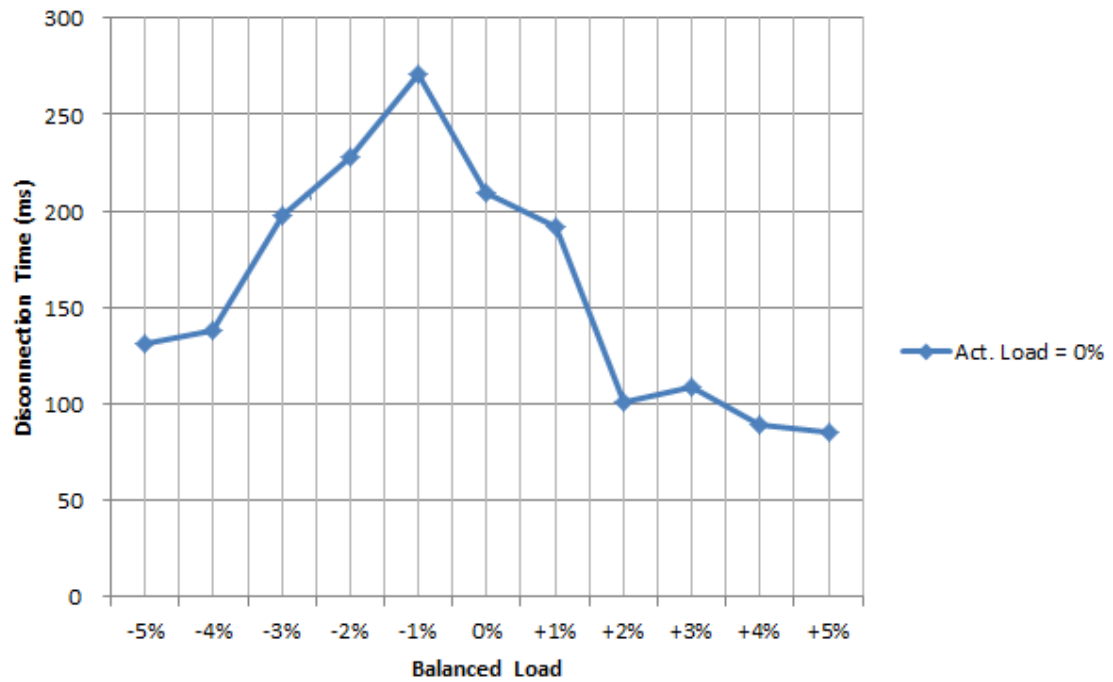

IEC 62116:2014 (50Hz)

Test Condition C

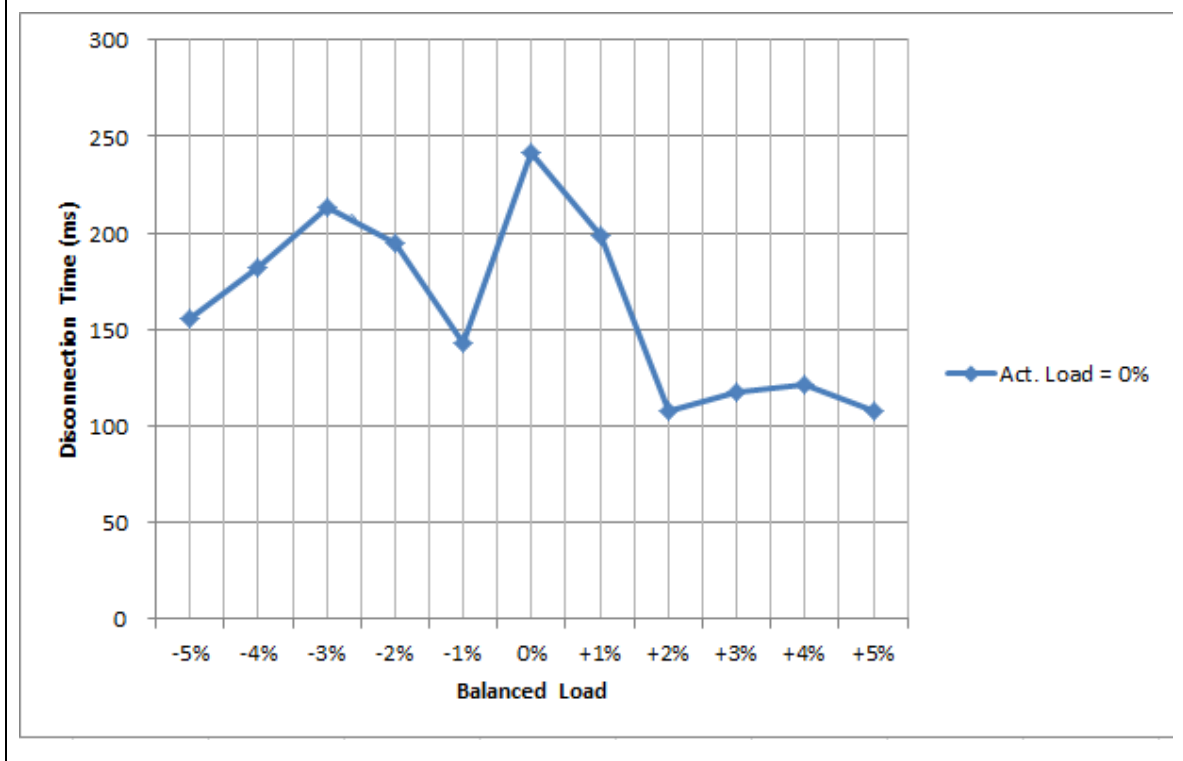

ATTACHMENT III

(GRAPHICS OF THE ISLANDING BEHAVIOR DETECTION)

1 DEFINITIONS

- M It represents the % change in active load from nominal output power
- N It represents the % change in reactive load from nominal output power

2 LEGEND



Colour	Label	Definition
	CH1	Grid Switch
	CH5	EUT Output current

Test A(50Hz)

M(%)=0 & N(%)=0

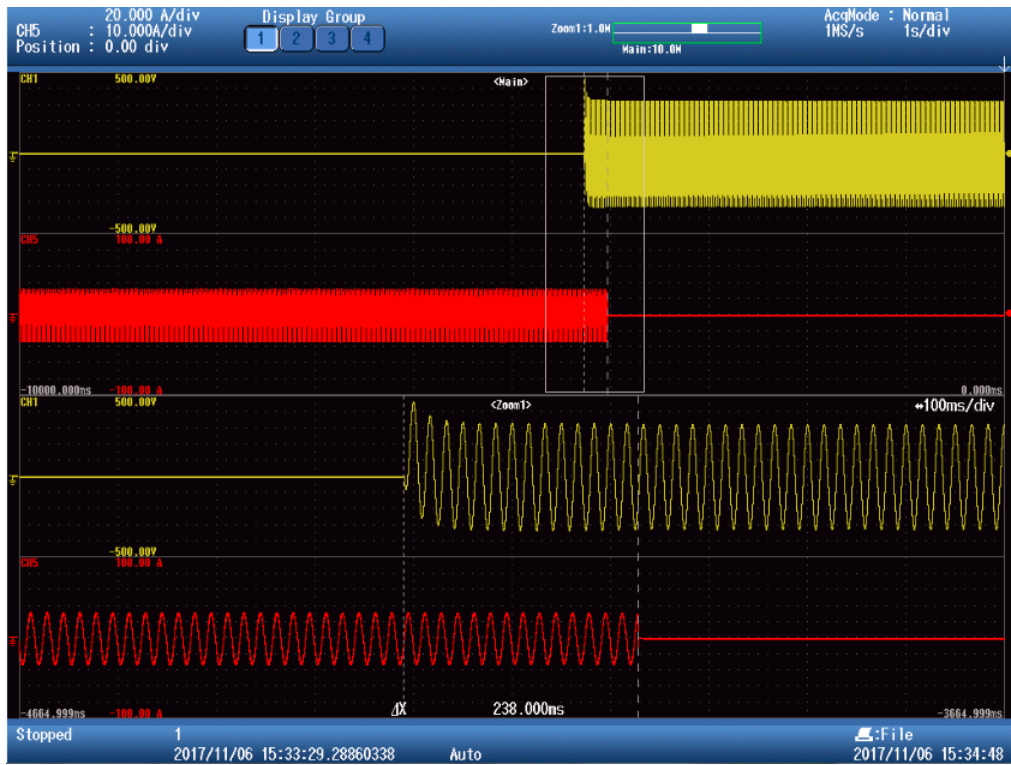

Test A(50Hz)

M(%)=0 & N(%)=+5



Test A(50Hz)

M(%)=0 & N(%)=-5

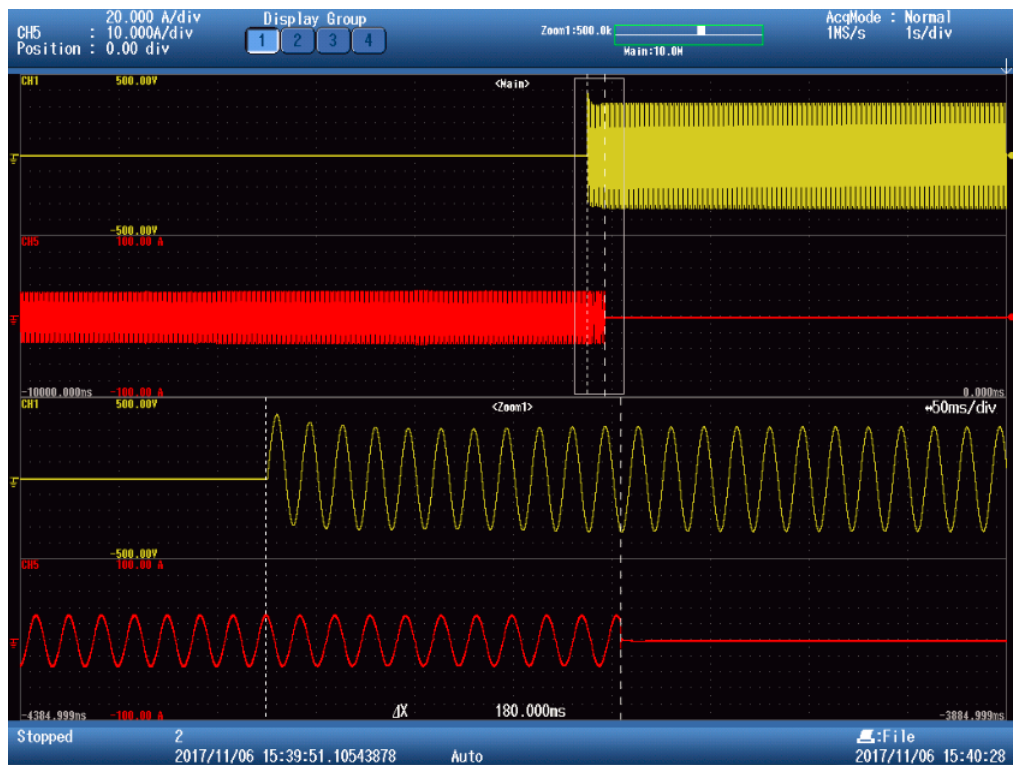

Test A(50Hz)

M(%)=+5 & N(%)=0



Test A(50Hz)

M(%)=+5 & N(%)=+5

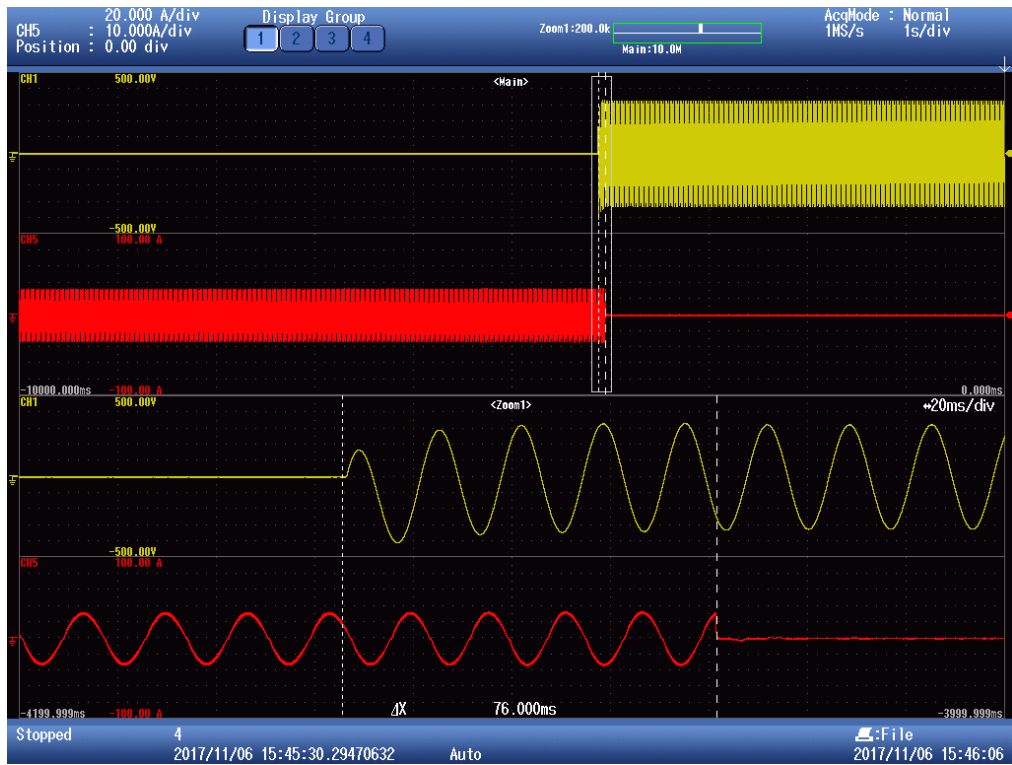

Test A(50Hz)

M(%)=+5 & N(%)=-5

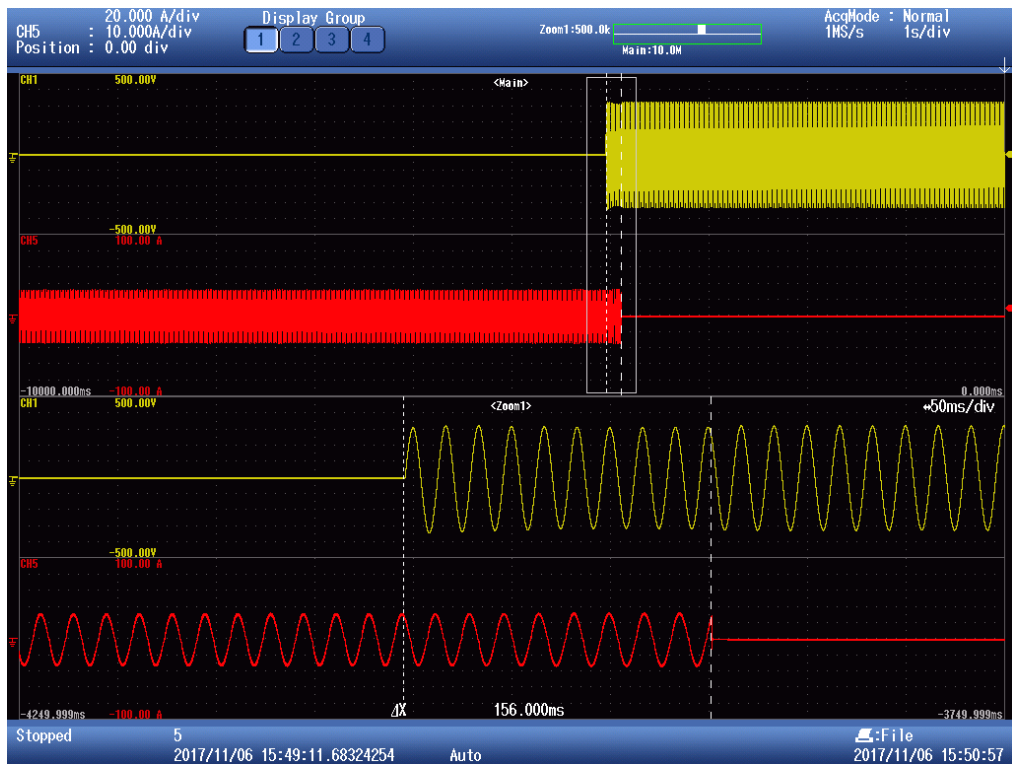

Test A(50Hz)

M(%)=-5 & N(%)=0

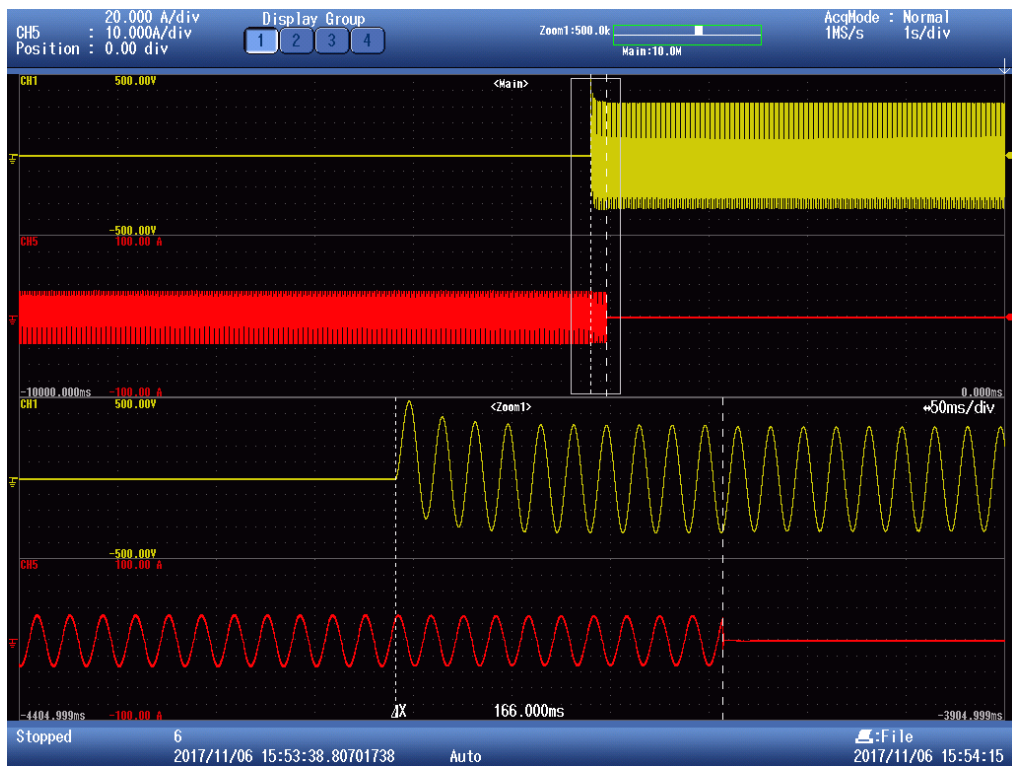

Test A(50Hz)

M(%)=-5 & N(%)=+5



Test A(50Hz)

M(%)=-5 & N(%)=-5

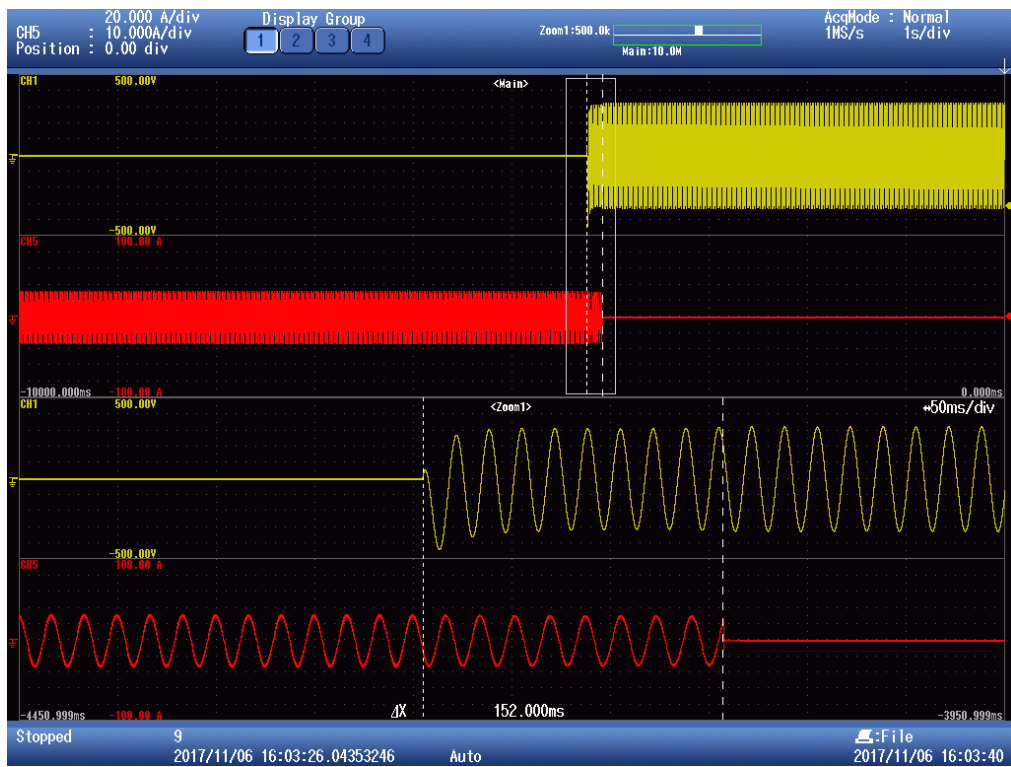

Test B(50Hz)

M(%)=0 & N(%)=0



Test B(50Hz)

M(%)=0 & N(%)=+1



Test B(50Hz)

M(%)=0 & N(%)=+2

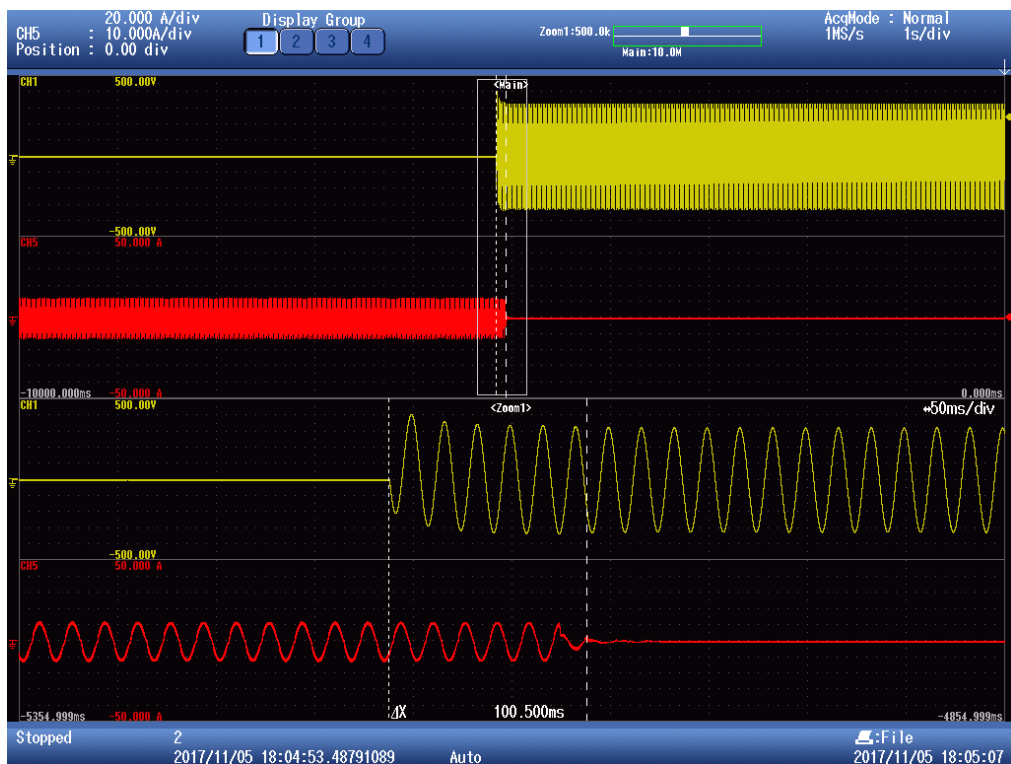

Test B(50Hz)

M(%)=0 & N(%)=+3



Test B(50Hz)

M(%)=0 & N(%)=+4

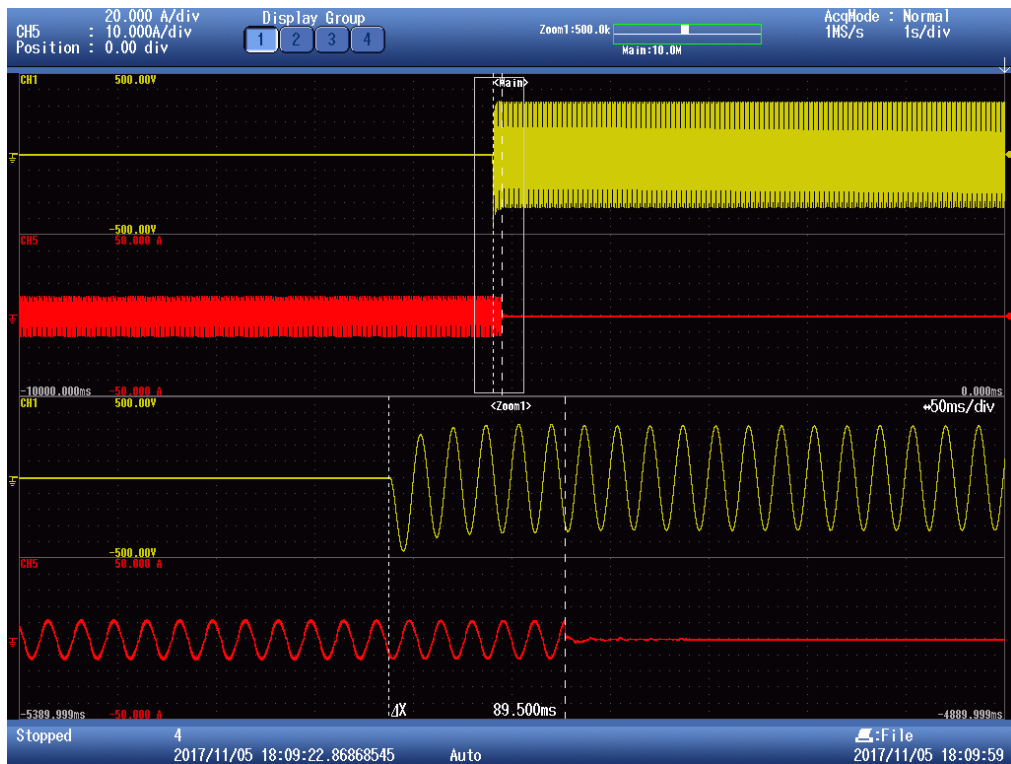

Test B(50Hz)

M(%)=0 & N(%)=-2

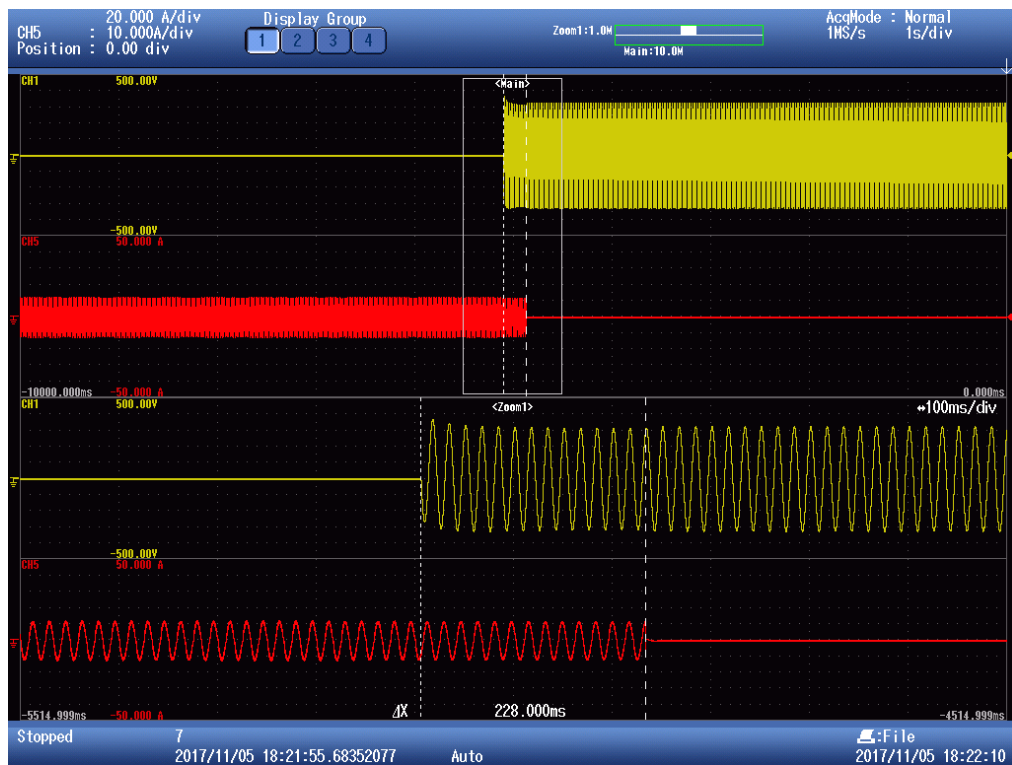

Test B(50Hz)

M(%)=0 & N(%)=-3

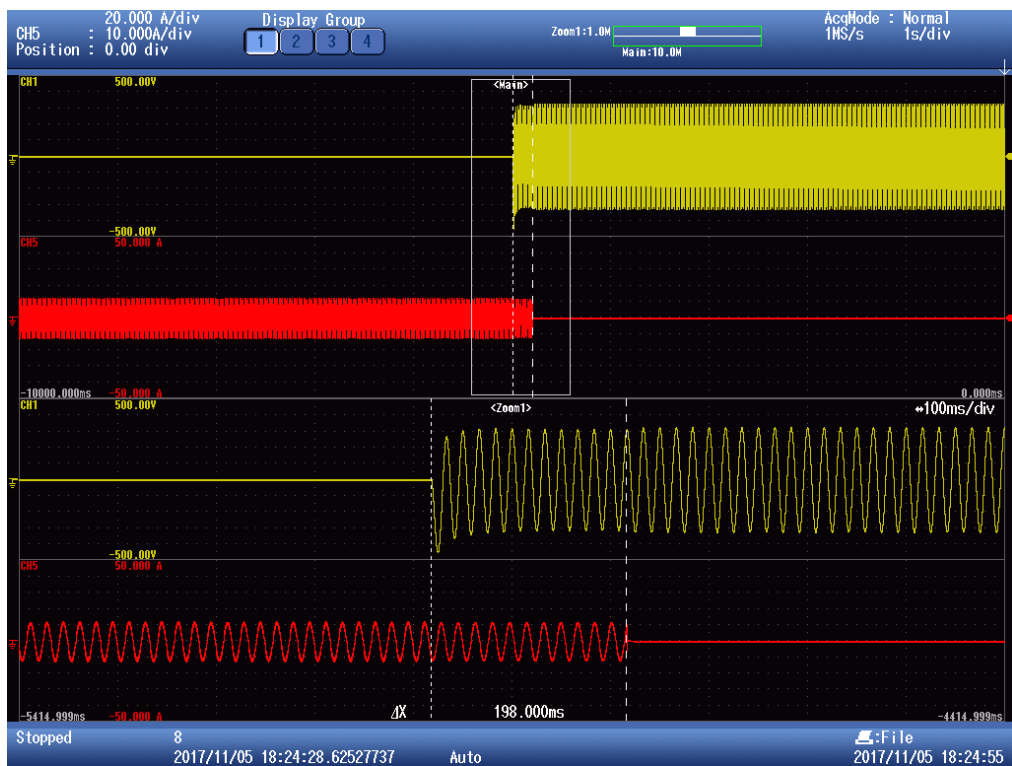

Test C(50Hz)

M(%)=0 & N(%)=0

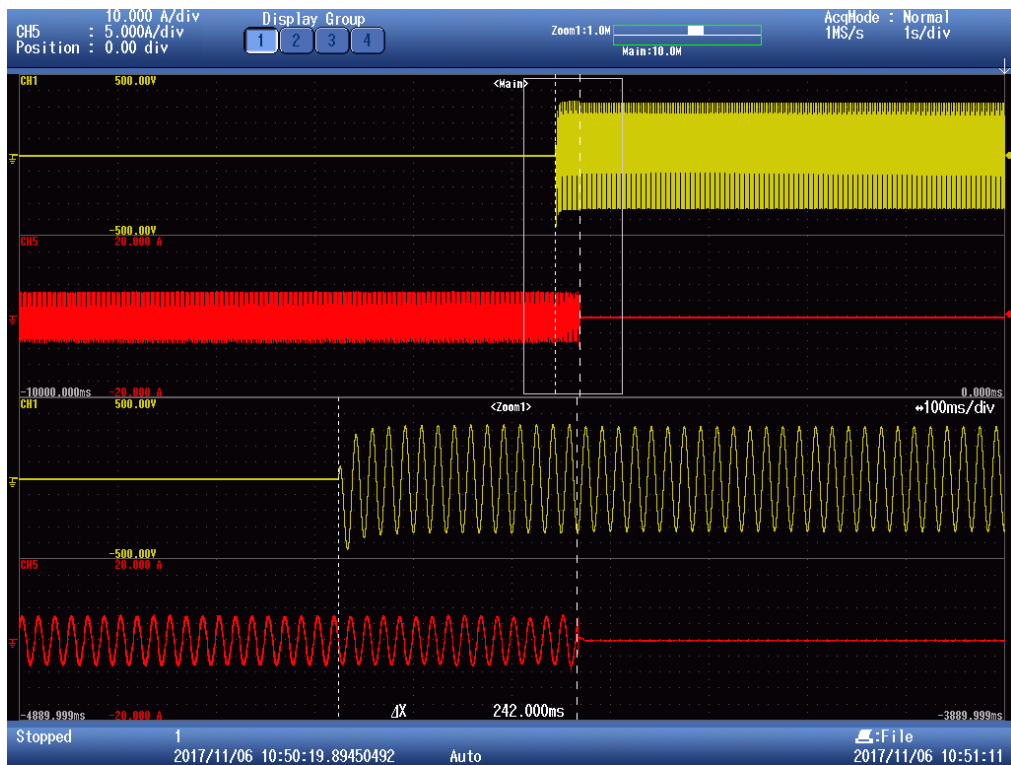

Test C(50Hz)

M(%)=0 & N(%)=+1



Test C(50Hz)

M(%)=0 & N(%)=+2



Test C(50Hz)

M(%)=0 & N(%)=+3



Test C(50Hz)

M(%)=0 & N(%)=+4

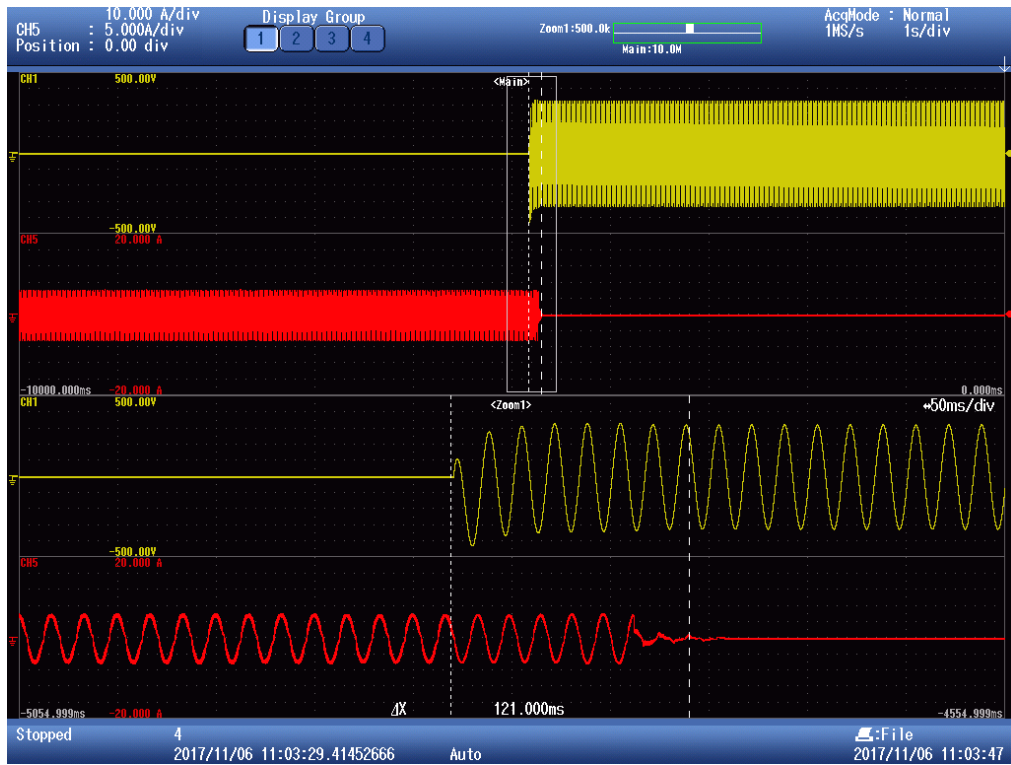

Test C(50Hz)

M(%)=0 & N(%)=+5

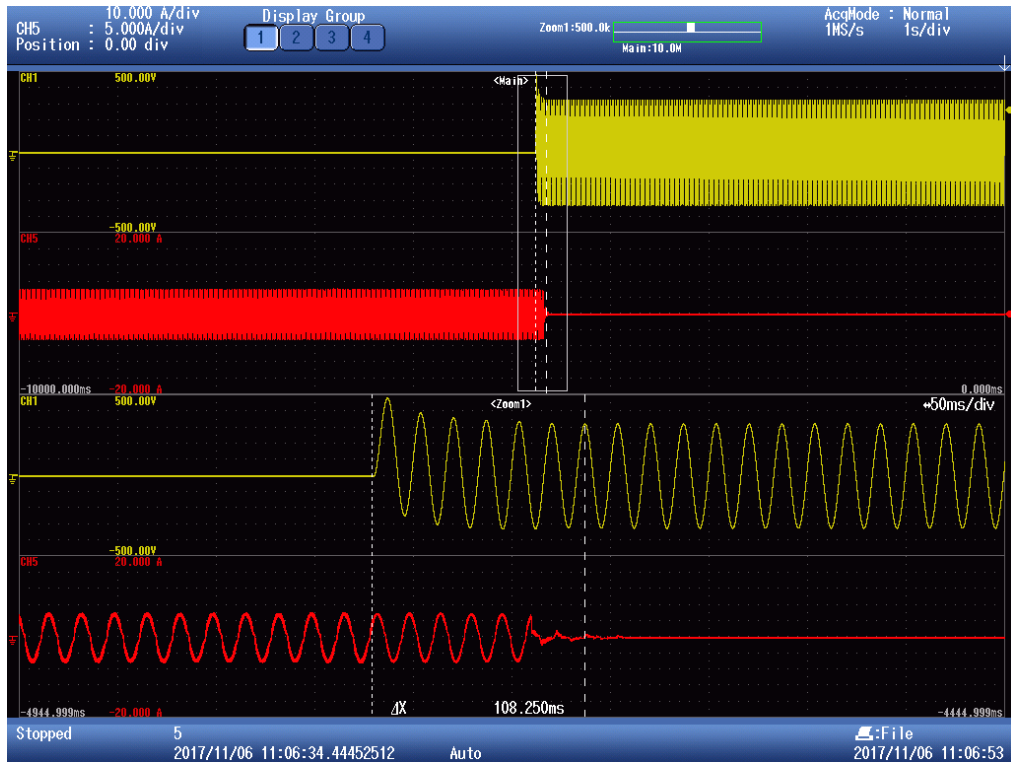

Test C(50Hz)

M(%)=0 & N(%)=-1



Test C(50Hz)

M(%)=0 & N(%)=-2



Test C(50Hz)

M(%)=0 & N(%)=-3

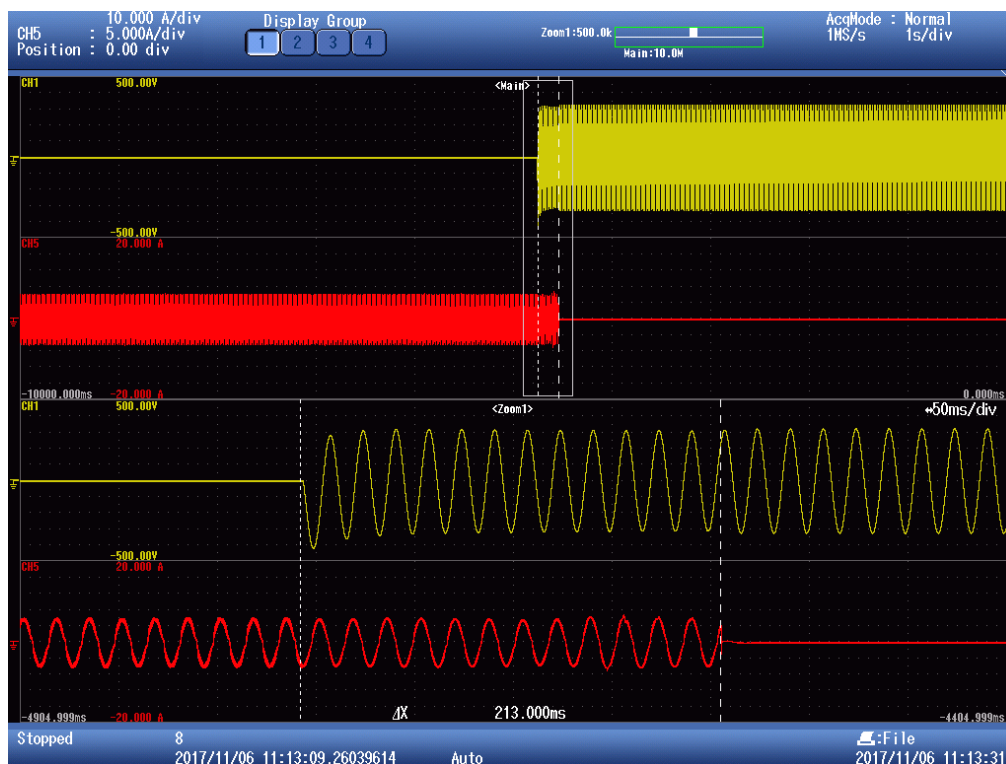

Test C(50Hz)

M(%)=0 & N(%)=-4

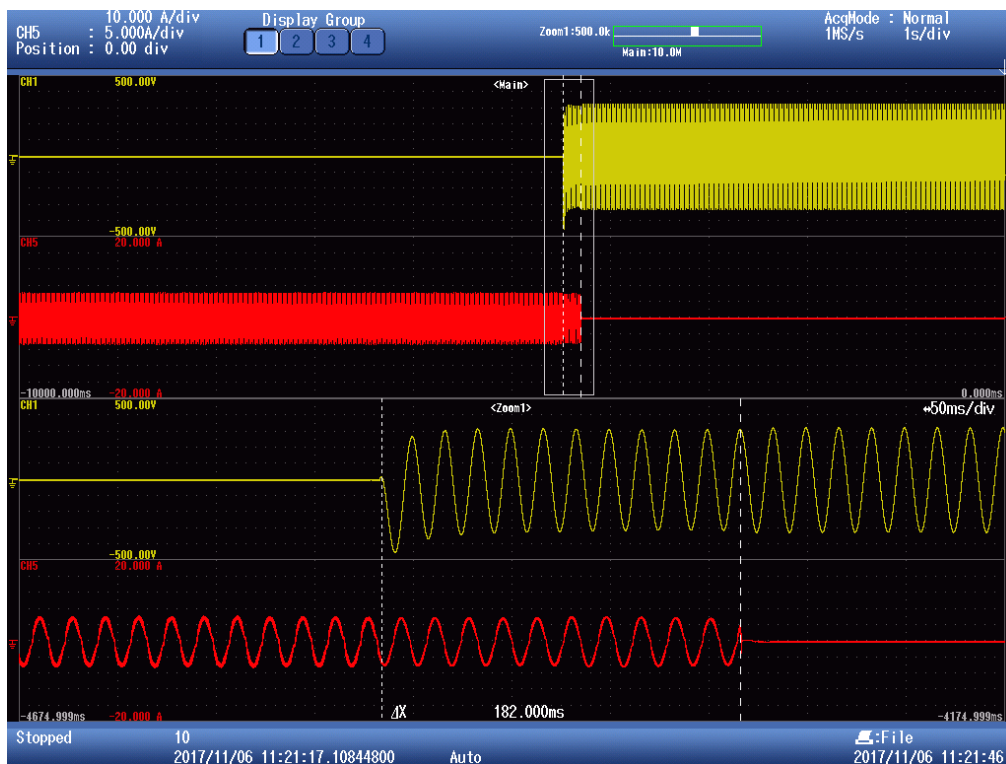

Test C(50Hz)

M(%)=0 & N(%)=-5



ATTACHMENT IV

(Testing information)

1 TESTING CIRCUIT

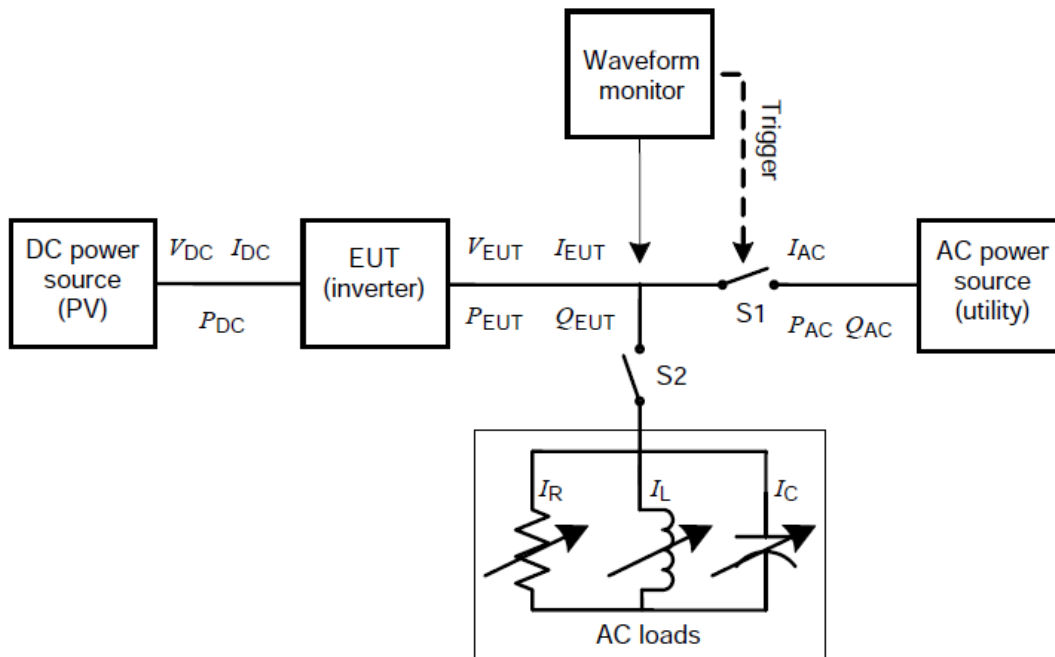

Current and voltage clamps have been connected to the inverter input/output for all the tests.
 All the tests and checks have been performed in accordance with the reference standard under testing.

2 TESTING EQUIPMENT

No.	Equipment Name	MARK/Model No.	Equipment No.	Equipment calibration due date
1	AC source	Chroma / 61860	--	--
2	PV array simulator	Chroma / 62150H-1000S	--	--
3	Current clamp	FLUKE / i1000s	30413441	2018-02-15
4	Differential probe	Sanhua / SI-9110	111134	2018-02-15
5	Temperature & Humidity meter	VICTOR / VC230A	WS01	2018-09-03
6	Power analyzer	YOKOGAWA / WT 3000	EP-011	2018-08-05
7	Digital oscilloscope	YOKOGAWA/DL 850	EP-001	2018-10-22

Items	Specifications
1) PV array simulator	
a) Voltage range	0 – 1000Vdc (0.01V step)
b) Current range	0 – 40A (0.01A step)
2) AC power source	
a) Output wiring	Three phase
b) Output capacity	100KVA
c) Output voltage	10-300Vrms
d) Output frequency	45-65Hz
e) Voltage stability	± 100ppm/°C
f) Output voltage distortion	0.05% max.
3) Digital meter	
a) Voltage range	0 – 1000Vdc, 0 – 600Vrms
b) Current range	0 – 30A
c) Frequency range (accuracy)	0.2%
d) Measurement items	Voltage (V) Current (A) Active power (W) Reactive power (Var) Volt-ampere (VA) Power factor (PF) Frequency (Hz) Electric energy (Wh)

IEC 62116:2014 (50Hz)

4) Waveform recorder	
a) Sampling speed	1M/s
b) Recording device	Memory record and USB reading
c) Time accuracy	± 500ppm
5) AC load	
a) Resistive load	Maximum voltage: 300Vrms Current range: 0 – 100A Capacity: 100KW
b) Inductive load	Maximum voltage: 300Vrms Current range: 0 – 100A Capacity: 100KVA
c) Capacitive load	Maximum voltage: 300Vrms Current range: 0 – 100A Capacity: 100KVA

3 MEASUREMENT UNCERTAINTY

Voltage measurement uncertainty	±0.05 %
Current measurement uncertainty	±0.05 %
Frequency measurement uncertainty	±0.001 Hz
Time measurement uncertainty	±0.001s
Power measurement uncertainty	±0.5 %
Phase Angle	±0.1°
Cosφ	±0.01%

Note1: Measurements uncertainties showed in this table are maximum allowable uncertainties. The measurement uncertainties associated with other parameters measured during the tests are in the laboratory at disposal of the solicitant.